

INSTRUCTION MANUAL SINGLE PHASE LOW-VOLTAGE HYBRID INVERTER



10 YEAR
WARRANTY*

INTRODUCTION

Thank you for selecting and buying V-TAC product. V-TAC will serve you the best. Please read these instructions carefully before starting the installation and keep this manual handy for future reference. If you have any other query, please contact our dealer or local vendor from whom you have purchased the product. They are trained and ready to serve you at the best. The warranty does not apply to damage caused by incorrect installation or abnormal wear and tear. The company gives no warranty against damage to any surface due to incorrect removal and installation of the product. This product is warranted for manufacturing defects only.

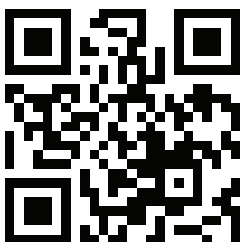

MULTI-LANGUAGE MANUAL QR CODE

Please scan the QR code to access the manual in multiple languages.



FR

Cet appareil,
ses accessoires
et cordons
se recyclent

À DÉPOSER
EN MAGASIN

À DÉPOSER
EN DÉCHÈTERIE



OU



Points de collecte sur www.quefairedemesdechets.fr
Privilégiez la réparation ou le don de votre appareil !

Contents

1 Overview	1
1.1 Scope of Application	1
1.2 Intended Users	1
1.3 Symbols Used in This Manual	1
2 Safety Precautions	3
2.1 Operation Safety	3
2.2 PV String Safety	3
2.3 Battery Safety	4
2.4 Inverter Safety	5
2.5 Personnel Requirements	5
2.6 Description of Symbols on the Inverter	5
3 Equipment Inspection and Storage	6
3.1 Inspection before Signing	6
3.2 List of Deliverables	6
3.3 Equipment Storage	10
4 Product Introduction	11
4.1 Overview	11
4.2 Application Scenarios	11
4.3 Working Mode	12
4.3.1 Self-use Mode (Default)	12
4.3.2 Time-of-use Mode	13
4.3.3 Disaster Backup Mode	13
4.3.4 Off-grid Mode	15
4.3.5 Schedule Charging/Discharging Mode	15
4.4 Inverter Running Status	15
4.5 Appearance Description	18
4.5.1 Appearance Introduction	18
4.5.2 Size Description	19
5 Installation	20
5.1 Installation Requirements	20

5.1.1 Installation Environment	20
5.1.2 Installation Carrier	20
5.1.3 Installation Angle	22
5.2 Installation Tools	22
5.3 Moving the Inverter	24
5.4 Inverter Installing	25
6. Electrical Connection	27
6.1 Electrical System Connection Diagram	27
6.2 Wiring Instructions for External Ports	28
6.3 Connecting Protective Earth (PE)	30
6.4 Connecting PV Cables	30
6.5 Connecting the Battery Cable	32
6.6 Connecting Off-grid Port (AC LOAD) and Grid-connected Port (AC GRID)	34
6.7 Installing WIFI/Bluetooth/4G Module	35
6.8 Connecting Communication Cables	37
6.9 Parallel Wiring Operation	40
6.10 Meter Operation and Display	41
7. Equipment Trial Run	46
7.1 Check before Power-on	46
7.2 First Power-on	48
8. System Commissioning	49
8.1 Indicator Description	49
8.2 App Introduction	49
9. Troubleshooting and Maintenance	50
9.1 Regular Maintenance	50
10. Technical Parameters	52

1 Overview

This Manual mainly introduces the product information, installation, electrical connection, configuration commissioning, troubleshooting and maintenance, and technical parameters of Residential energy storage single-phase hybrid inverter. Before installing and using this product, please read this Manual carefully to understand the safety information and be familiar with the functions and features of the product. The Manual is subject to update. Please obtain the latest version from the official website to get more product information.

1.1 Scope of Application

This document applies to the inverters of the following models:





Model	Rated output power	Rated output voltage
Isuna 3000S	3000W	220/230V/240V, L/N/PE
Isuna 3600S	3600W	
Isuna 4000S	4000W	
Isuna 4600S	4600W	
Isuna 5000S	5000W	
Isuna 6000S	6000W	

1.2 Intended Users

This Manual is only suitable for professional technicians who are familiar with local regulations, standards and electrical systems, have received professional training, and are familiar with the relevant knowledge of this product.

1.3 Symbols Used in This Manual

In order to ensure the user's personal and property safety when using the PV grid-connected inverter, and to use the product efficiently, relevant safety operation information is provided in this Manual and highlighted with corresponding symbols. Please fully understand and strictly abide by below emphasized information to avoid personal injury and property damage. The symbols used in this manual are listed below.

 <p>Danger</p>	<p>It indicates a highly potential hazard which, if not avoided, will result in death or serious injury.</p>
 <p>Warning</p>	<p>It indicates a hazard with a medium level of potential which, if not avoided, could result in death or serious injury.</p>
 <p>Caution</p>	<p>It indicates a hazard with a low level of potential which, if not avoided, could result in moderate or minor injury.</p>
 <p>Attention</p>	<p>It indicates a potential hazard which, if not avoided, could result in the equipment malfunction or property damage.</p>
 <p>Note</p>	<p>It indicates the emphasis and supplementary instructions on the content, and may also provide tips for optimizing the product use, which can help you solve a certain problem or save your time.</p>

2 Safety Precautions

The safety precautions information contained in this document must always be followed when operating the equipment.

	<ul style="list-style-type: none">➤ The inverter has been designed and tested in strict accordance with safety regulations. However, as an electrical device, relevant safety instructions must be followed before any operation. Improper operation may cause serious injury or property loss.
---	---

2.1 Operation Safety

	<ul style="list-style-type: none">➤ Please read this manual carefully to fully understand the product and precautions before installing the equipment.➤ All operations of the equipment must be carried out by professional electrical technicians, and the technicians need to be familiar with the relevant standards and safety regulations of the project location.➤ When operating the inverter, use insulated tools and wear personal protective equipment to ensure personal safety. When touching electronic devices, wear ESD gloves, ESD wrist straps, and ESD clothing to prevent the inverter from being damaged by static electricity and causing losses.➤ Machine damage or personal injury caused by installation, use, and configuration not in accordance with the requirements of this Manual is not within the scope of the equipment manufacturer's responsibility.
---	--

2.2 PV String Safety

	<ul style="list-style-type: none">➤ Please use the DC terminals provided with the box to connect the DC cables of the inverter. If other types of DC terminals are used, serious consequences may result, and the manufacturer isn't responsible for equipment damage therefrom.
	<ul style="list-style-type: none">➤ Please ensure that the frame of the module and the bracket system are properly grounded.



Warning

- After the DC cable is connected, please ensure that the cable connection is tight and firm.
- Use a multimeter to measure whether the positive and negative poles of the DC terminal of the battery are connected correctly and the voltage is within the allowable range.
- Do not connect the same PV string to multiple inverters, or the inverters will be damaged.

2.3 Battery Safety



Warning

- Please carefully read the content about battery safety introduced in the Manual before installing the equipment, and operate in strict accordance with the requirements in the Manual.
- If the battery has been fully discharged, please charge the battery strictly according to the corresponding type of battery in the Manual.
- The battery current may be affected by the external environment, such as temperature and humidity, which may cause the battery current limit and affect the battery load performance.
- If the battery fails to start, please contact the after-sales service center as soon as possible. Otherwise, the battery may be permanently damaged.
- Use a multimeter to measure whether the positive and negative poles of the DC terminal of the battery are normal and the voltage is within the allowable range.
- Do not connect the same battery pack to multiple inverters, or the inverter will be damaged.

2.4 Inverter Safety

	<ul style="list-style-type: none"> ➤ Please ensure that the voltage and frequency of the grid connection meet the specifications of the inverter. ➤ It is recommended to add protection devices such as circuit breakers or fuses on the AC side of the inverter. The specification of the protection device must be greater than 1.25 times the maximum AC output current of the inverter. ➤ The protective grounding wire of the inverter must be firmly connected. When multiple inverters are paralleled, ensure that the protective grounding points of all inverter chassis shells are equipotentially connected. ➤ If no battery is configured in the PV system, it is not recommended to use the BACK-UP off-grid function, and the resulting system power consumption risk will not be covered by the equipment manufacturer's warranty.
---	---





2.5 Personnel Requirements

	<p>When the inverter is running, some components may be electrified or hot. Improper use, incorrect installation or operation may result in serious personal or property injury. Transport, installation, disassembly, start-up and maintenance operations must be performed by qualified electrical engineers.</p>
---	---

2.6 Description of Symbols on the Inverter

There are some safety-related labels on the residential energy storage single-phase hybrid inverter. Please carefully read and fully understand the content of these labels before installing the product.

Symbol	Description	Meaning
	<p>Residual voltage in the inverter</p>	<p>After the inverter is powered off for a period of time, the internal capacitor is still charged. Please wait for more than 5 minutes until the capacitor is completely</p>

		discharged.
	High voltage	There is high voltage during the operation of the inverter. If you need to operate the inverter, please ensure that the inverter is powered off.
	Be careful of hot surface	The casing of the inverter is very hot when it is running. Do not touch it, or it may cause burns.
	Ground terminal	Connect the inverter to the ground to achieve the purpose of ground protection.
	Read the Manual	Before installing the inverter, please carefully read and understand this Manual.

3 Equipment Inspection and Storage







3.1 Inspection before Signing



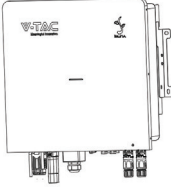

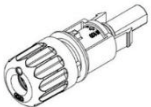
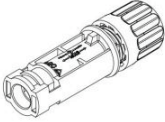



Before signing for the product, please check the following in detail:

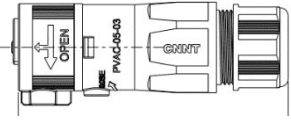

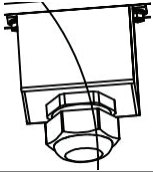
- Check whether the outer package is damaged, such as holes, deformation, cracks or other signs that may cause damage to the equipment in the box. If there is any damage, do not open the package and contact your dealer.
- Check whether the inverter model is correct; if not, do not open the package and contact your dealer.
- Check whether the type and quantity of deliverables are correct, and whether the appearance is damaged. In case of damage, please contact your dealer.

3.2 List of Deliverables

After unpacking the inverter, check whether the deliverables are complete. If any components are missing or incomplete, please contact the dealer in time.

No.	Picture	Description	Quantity
1		Inverter	1PCS
2		Wall mounted back panel	1PCS
3		PV+ wire input terminal molded case	2PCS
4		PV- wire input terminal molded case	2PCS
5		PV+ input terminal metal core	2PCS
6		PV- input terminal metal core	2PCS
7		Battery terminal box	1PCS

8		AC terminal block	2PCS
9		Single-phase electric meter (optional)	1PCS
10		Signal interface waterproof cover	1PCS
11		WIFI module (optional)	1PCS
12		Parallel communication line	1PCS
13		BMS communication line	1PCS
14		RJ45 terminal	2PCS
15		M8*80 expansion bolt	4PCS
16		M6 inner hexagon screw	4PCS

17		User Manual	1PCS
18		Warranty Card	1PCS
19		Desiccant	1PCS

3.3 Equipment Storage

If the inverter will not be put into use immediately, please store it according to the following requirements:

- Make sure that the outer packing box is not removed, and the desiccant in the box is not lost.
- Make sure the storage environment is clean and the temperature and humidity range is appropriate.
- Make sure that the stacking height and direction of the inverter comply with the instructions on the label on the packing box.
- Make sure that there is no risk of tipping over after the inverters are stacked.
- After the inverter has been stored for a long time, it must be checked and confirmed by professionals before it can continue to be used.

4 Product Introduction

4.1 Overview

Residential energy storage single-phase hybrid inverter integrates PV grid-connected inverter and battery energy storage, and has built-in multiple working modes to meet the diverse needs of users. In the period of rising energy costs such as oil and coal, the declining energy subsidies of PV grid-connected systems, mountainous areas without grids or base stations with uninterrupted power supply and emergency power supply needs, Residential energy storage single-phase hybrid inverter can provide a complete solution.

4.2 Application Scenarios



Warning

- PV system is not suitable for connecting devices that depend on stable power supply, such as life-sustaining medical equipment, etc. Please ensure that no personal injury will be caused when the system is powered off.
- In the PV system, please try to avoid using loads with high starting current, or the off-grid output may fail due to excessive instantaneous power.
- When the overload protection of the inverter occurs once, the inverter can automatically restart; if it occurs multiple times, the inverter will stop, and it can be restarted through the APP after the fault is eliminated.
- When the grid is powered off, if the load capacity exceeds the rated power of the inverter, the off-grid function of the inverter will be automatically turned off; if it needs to be started, the large load must be turned off to ensure that the load power is less than the rated power of the inverter.
- When the inverter is in off-grid mode, it can be used by ordinary household loads.
- Inductive load: It supports up to 1.5P non-inverter air conditioners. Connecting two or more non-inverter air conditioners may lead to unstable standby mode.

	➤ Capacitive load: total power $\leq 0.66 \times$ rated output power of inverter.
--	---

4.3 Working Mode

Note: The anti-reverse function is disabled by default.

4.3.1 Self-use Mode (Default)

Function:

Prioritize the use of PV and battery energy, and try not to use the energy of the grid.

Specific working method:

- When the PV is sufficient, the PV will give priority to powering the AC load ① and general load ③, then charge the battery ②, and the remaining energy can be connected to the grid ④.

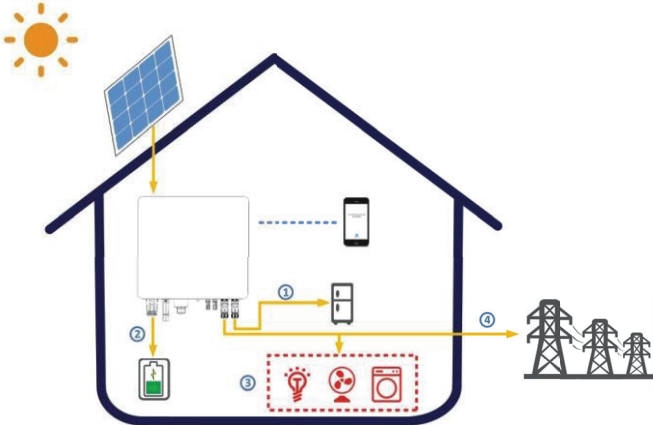

- When the PV is insufficient, the PV, the battery, and the grid jointly supply power to the load.

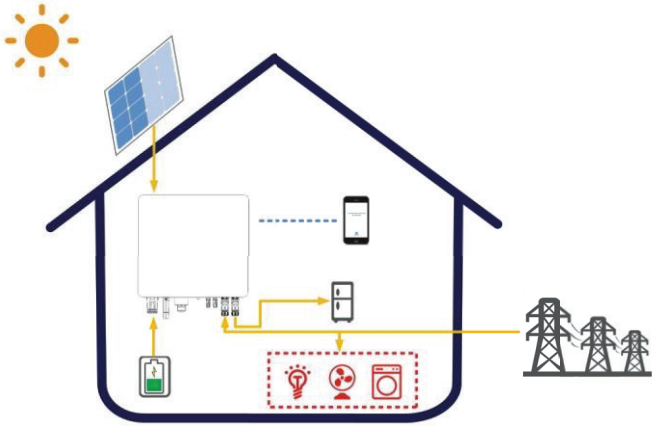

- When the PV is not working, the battery ② and the grid ④ jointly supply power to the load together (priority to the battery ②).

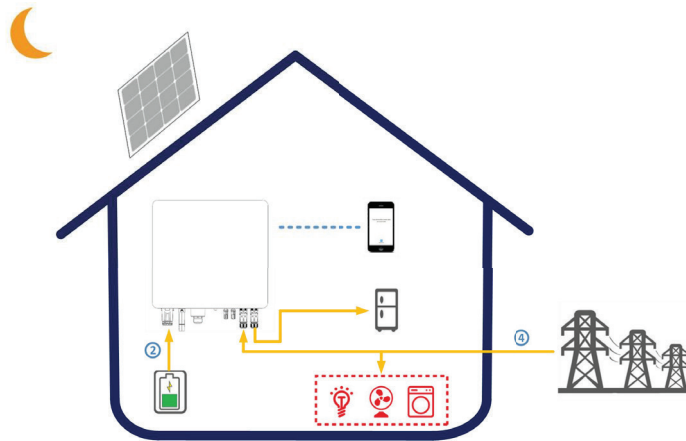

4.3.2 Time-of-use Mode

Function:

According to the electricity prices at different times, during the valley period: the grid and PV give priority to supplying power to the AC load, and the remaining energy is used to charge the battery; in other periods, it is in self-use mode.

Specific working method:

- During the valley period: the power grid ④ and PV give priority to supplying power to the AC load ①, and the remaining energy is used to charge the battery ②.

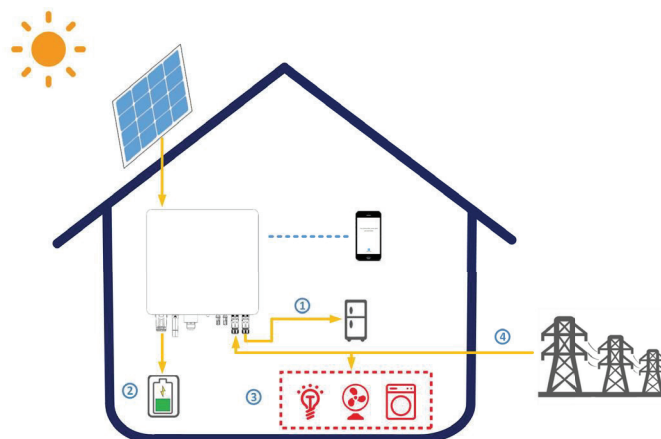

- Other periods: Self-use

4.3.3 Disaster Backup Mode

Function:

In the event of abnormal power grid, the energy storage system will provide power to the user alone. This mode can still maintain power supply when the user encounters a special situation such as an abnormal grid utility. (The battery needs to be charged and discharged every six months, which needs to be set manually)

Specific working method:

- PV and the grid jointly supply power to the battery and the load (the PV is given priority to charging the battery).

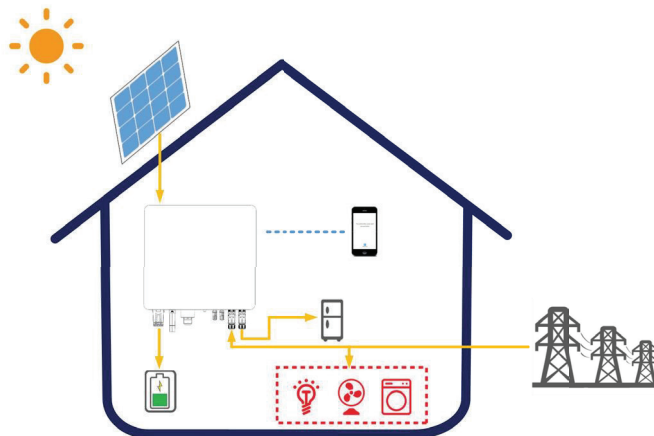

- The battery SOC is always fully charged when the grid utility is normal.

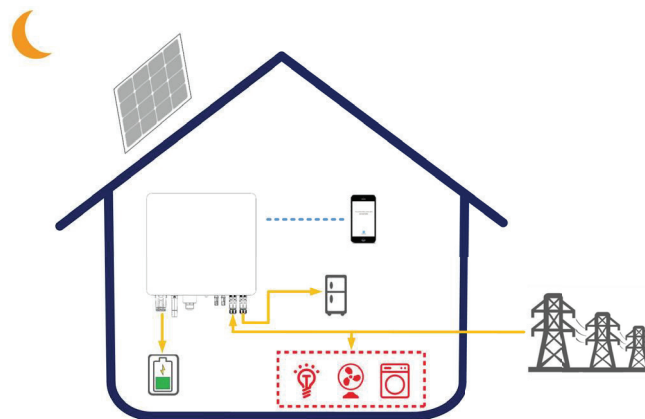

- The battery will discharge only when the grid utility is abnormal.

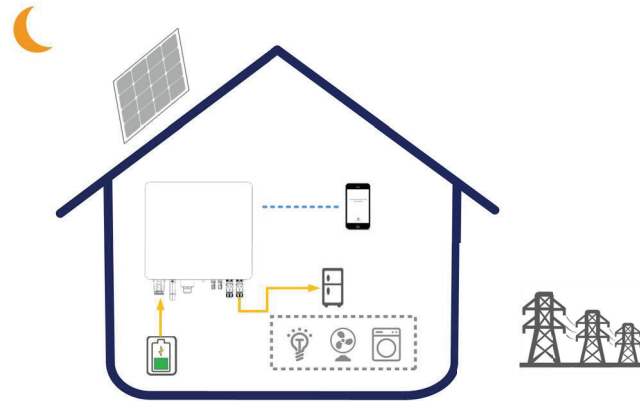

4.3.4 Off-grid Mode

Function:

PV and batteries form an off-grid system, and the inverter is used without grid power.

Specific working method:

- If the PV is sufficient, the PV will give priority to supplying power to the AC load ①, and the excess energy is used to charge the battery ②.

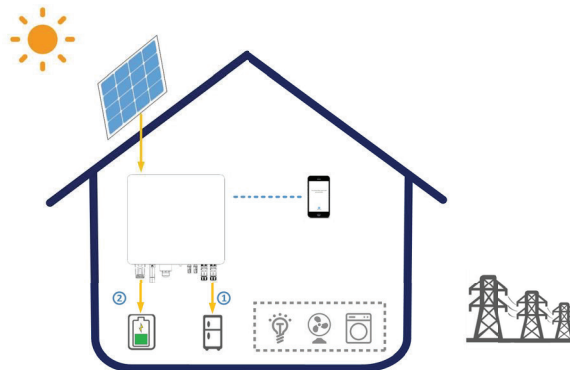

- If the PV is not working, the battery supplies power to the AC load.

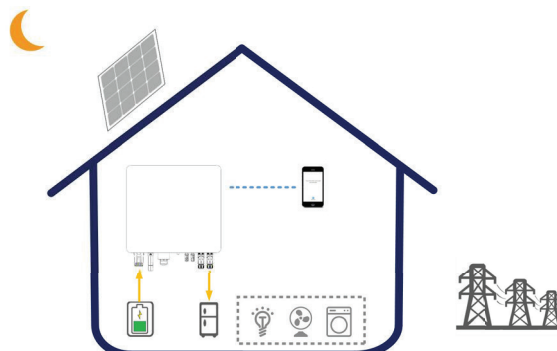

4.3.5 Schedule Charging/Discharging Mode

Function:

Set the charging and discharging time according to the user's needs.

Specific working method:

Set the charging and discharging schedule of the battery according to your own needs.

If the power outage notification is known in advance, the battery can be fully charged in advance to prepare for the use of household loads during power outages.

4.4 Inverter Running Status

Table 4-1 Description of inverter running status

No.	Running status	Description
1	Waiting	<ul style="list-style-type: none"> ➤ After the machine is powered on, it enters the waiting stage. ➤ When the conditions are met, it enters the self-check. ➤ If there is a fault, the inverter enters the fault state.
2	Self-check	<ul style="list-style-type: none"> ➤ Self-check and initialization are performed continuously before the inverter starts. ➤ If the conditions are met, it will enter the grid-connected mode, and the inverter starts grid-connected operation. ➤ If the grid is not detected, it will enter the off-grid state, and the inverter will run off-grid. ➤ If the self-check fails, it will enter the fault state.
3	Grid-connected	<ul style="list-style-type: none"> ➤ The inverter is normally connected to the grid. ➤ If it is detected that the grid does not exist, it will enter the off-grid working mode. ➤ If a fault is detected, it will enter the fault state. ➤ If it is detected that the grid conditions do not meet the grid-connection requirements, and the off-grid output function is not enabled, it will enter the waiting state. ➤ If switch to off-grid mode, it is detected that the grid conditions meet the grid-connection requirements, and the grid-connection function is enabled, it will enter the grid-connection state.
4	Off-grid	<ul style="list-style-type: none"> ➤ When the grid is powered off, the inverter will switch to off-grid mode and continue to supply power to the load.

		<ul style="list-style-type: none"> ➤ When the working mode is set to off-grid before running, the inverter works off-grid. ➤ When the off-grid mode is set during operation, it needs to be turned off and on again, and the off-grid mode will take effect. ➤ If a fault is detected, it will enter the fault state.
5	Fault	<ul style="list-style-type: none"> ➤ If a fault is detected, the inverter enters the fault state, and after the fault is cleared, it resumes the previous operation mode.

4.5 Appearance Description

4.5.1 Appearance Introduction

Please check the product packaging and accessories carefully before installation.

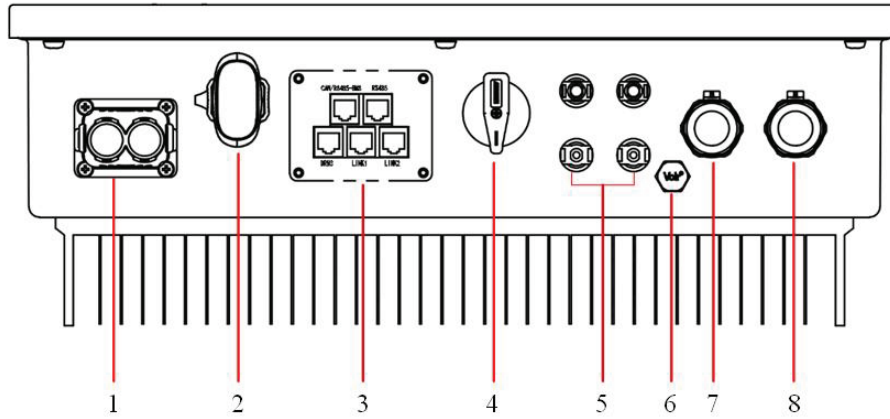
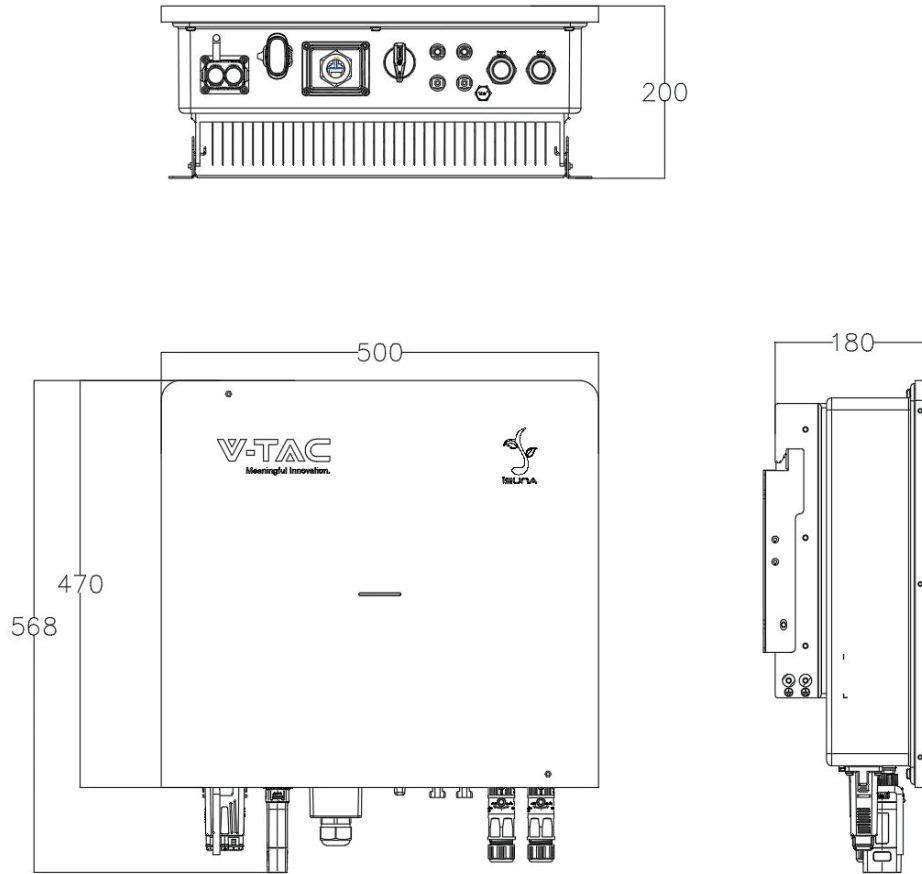

Table 4-2 Definition of external terminals

1	Battery DC input port (BAT+/-)	5	PV DC input port (PV+/-)
2	WIFI/4G/Bluetooth	6	Explosion-proof ventilation device
3	Multifunctional communication interface	7	Grid-connected AC wiring port
4	PV DC input switch	8	Load wiring port

4.5.2 Size Description

Inverter dimensions



Wall hanging size chart

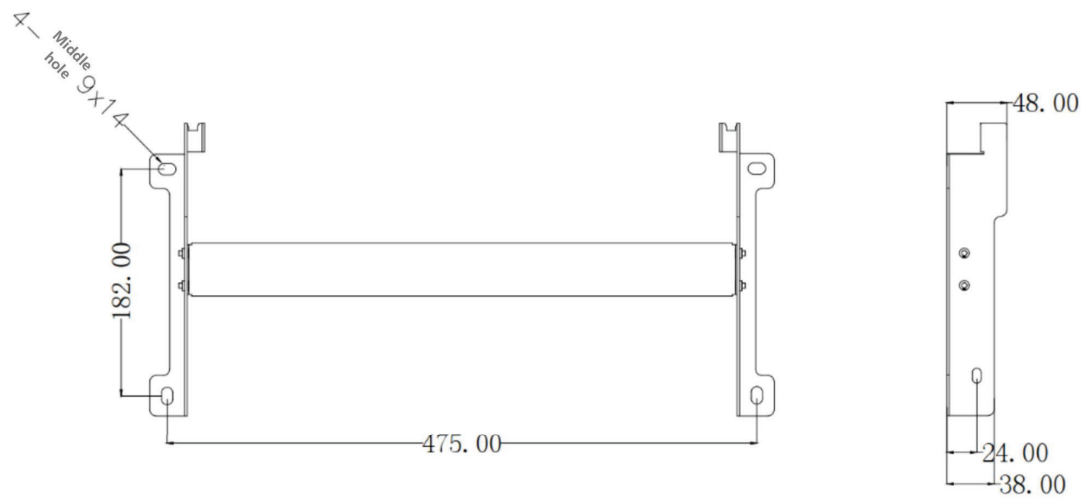

5 Installation

5.1 Installation Requirements

5.1.1 Installation Environment

- 1) Do not install the equipment in flammable, explosive or corrosive environments.
- 2) Please keep away from the water pipes and cables in the wall at the installation location to avoid danger when drilling holes.
- 3) The installation location should be kept out of the reach of children, and should not be installed in places that are easy to touch. The surface may be hot when the equipment is in operation. Be careful to prevent burns.
- 4) The installation environments of inverter need to avoid direct sunlight, rain and snow. It is recommended to install it in a sheltered installation location. If necessary, a sunshade can be built.
- 5) The installation space must meet the equipment ventilation and heat dissipation requirements and operating space requirements.
- 6) The protection level of the equipment meets indoor and outdoor installation, and the temperature and humidity of the installation environment must be within the appropriate range.
- 7) Please ensure that the indicator lights and all labels of the equipment are easily visible and the terminal blocks are easily accessible.
- 8) The inverter installation altitude is lower than the maximum working altitude of 4000m.
- 9) Keep away from strong magnetic field environment to avoid electromagnetic interference. If there are radio stations or wireless communication equipment below 30MHz near the installation location, please install the equipment according to the following requirements:
 - Add a multi-turn ferrite core to the DC input line or AC output line of the inverter, or add a low-pass EMI filter.
 - The distance between the inverter and the wireless electromagnetic interference device exceeds 30m.

5.1.2 Installation Carrier

- 1) The installation carrier must not be a flammable material and must have fire resistance.

2) Please ensure that the installation carrier is firm and reliable, and can bear the weight of the inverter.

3) When the equipment is running, it will emit noise. Do not install it on a carrier with poor sound insulation, so as to avoid the noise generated by the equipment when it is working, causing troubles to the residents in the living area.



5.1.3 Installation Angle

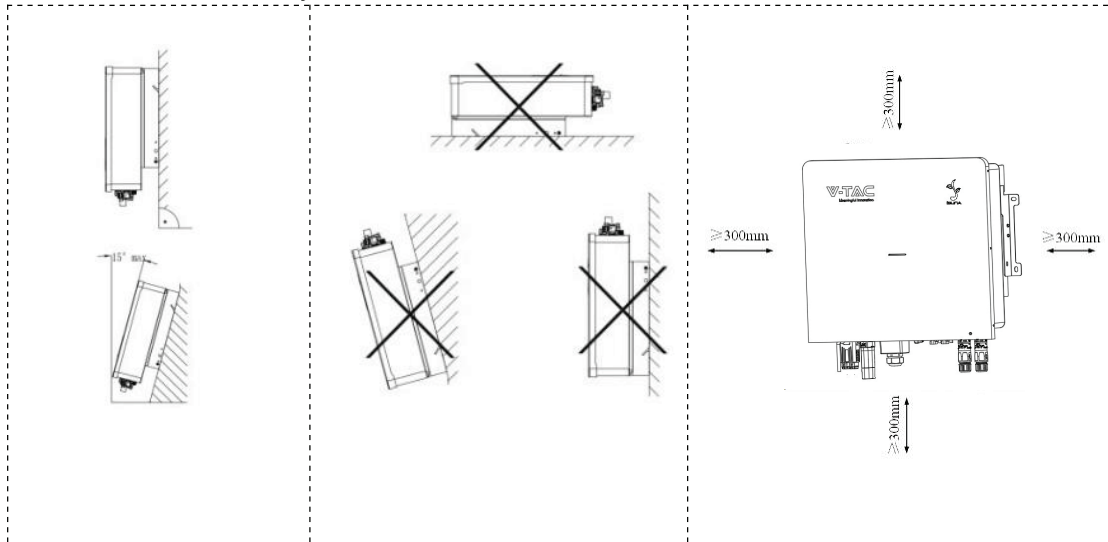



- 1) Recommended inverter installation angle: vertical or backward $\leq 15^\circ$.
- 2) Do not install the inverter upside down, tilt forward or backward beyond the angle, or install it horizontally.

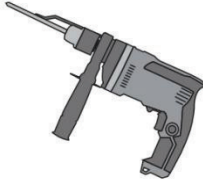
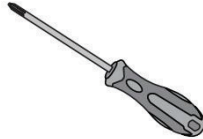



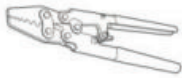

5.2 Installation Tools

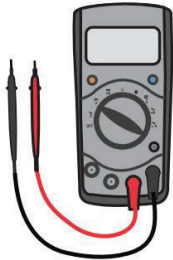
Table 5-1 List of installation tools

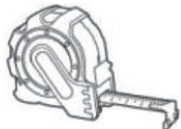
No.	Tool	Description	Function
1		Impact drill 8mm drill bit recommended	For drilling in wall
2		6mm cross screwdriver	For removing and installing screws and wiring
3		4mm cross screwdriver	For removing and installing load terminal screws

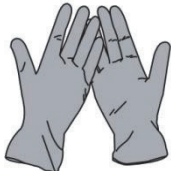
4		Removal tool	For removing PV terminal
5		Wire strippers	For wire stripping
6		Crimping pliers	For crimping power cables
7		Crimping pliers	For crimping signal network cable
8		6mm inner hexagonal wrench	For fastening the grid terminal and the cable
9		Multimeter	Check whether the cable connection is correct, whether the positive and negative poles of the battery are correct, whether the grounding is reliable, and whether the voltage is within

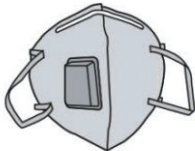
			the specification range
10		Marker pen	Mark for drilling
11		Measuring tape	For measuring distance
12		Level ruler	To ensure the level of the back panel
13		Protective gloves	Wear when installing the machine
14		Goggles	Wear when drilling
15		Dust mask	Wear when drilling

5.3 Moving the Inverter

Take the inverter out of the package and move it horizontally to the designated installation location. Open the outer packing box, two operators respectively put their hands under the inverter radiator, move the inverter out of the outer packing box, and move it to the designated installation location.

 Attention	<ul style="list-style-type: none">➤ When carrying out operations such as transportation, turnover, and installation, the laws, regulations, and relevant standards of the country and region where it is located must be met.➤ Since the inverter is heavy, please keep the balance when carrying it, so as not to hurt the operators when the machine falls.➤ The power line interface and signal line interface at the bottom of the inverter can't bear the load. Do not make the terminal directly contact the ground. Please place the inverter horizontally.➤ When the inverter is placed on the ground, place foam or cardboard under it to avoid damage to the casing.
--	---

5.4 Inverter Installing

 Attention	<ul style="list-style-type: none">➤ When drilling, ensure that the drilling position avoids water pipes and cables in the wall to avoid danger.➤ When punching holes, please wear goggles and dust mask to prevent dust from being inhaled into the respiratory tract or falling into the eyes.
---	--

Step 1: Please choose a wall with sufficient bearing capacity, attach the wall mount to the installation wall horizontally, mark the position on the wall where the wall mount needs to be drilled with a marker pen, and then use an impact drill to drill holes on the wall. When drilling, keep the impact drill perpendicular to the wall. Do not shake it, so as not to damage the wall. If the hole drilling error is large, it needs to be repositioned;

Step 2: Insert the M8*80 expansion bolt vertically into the hole. The insertion depth of the expansion bolt should not be too shallow;

Step 3: Align the hole position of the wall mount, and fix the wall mount to the wall with nuts;

Step 4: Hang the inverter on the wall mount, ensure that the inverter is correctly inserted into the wall mount slot, then fix the inverter to the wall mount with 2*M6 hexagon screws.

Step 5: In order to prevent theft, the user can configure a suitable small lock to lock the inverter and the wall mount (optional).

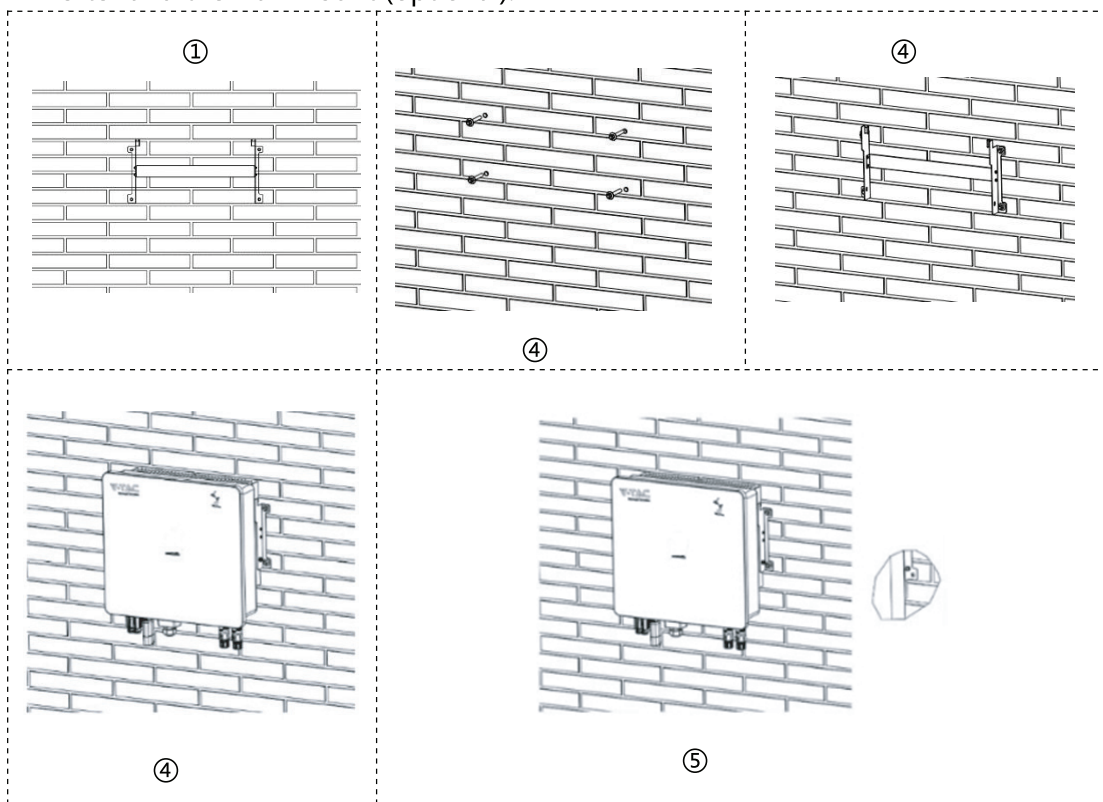

6. Electrical Connection

Before installation and maintenance, ensure that the AC and DC sides are disconnected. Since the capacitor is still charged after the inverter is powered off, it is necessary to wait for at least 5 minutes to ensure that the capacitor is fully discharged. Residential Hybrid inverters are used in battery energy storage PV systems. The inverter may be damaged if it is not used as intended.

6.1 Electrical System Connection Diagram

 Attention	<ul style="list-style-type: none">➤ According to the regulatory requirements of different regions, the wiring methods of the N wire and PE wire of the AC-GRID and AC-LOAD ports of the inverter are different. The specific requirements of the local regulations shall prevail.➤ The AC-GRID and AC-LOAD ports of the inverter have built-in relays. When the inverter is in the off-grid mode, the built-in AC-GRID relay is in the disconnected state; when the inverter is in the grid-connected mode, the built-in AC-GRID relay is in the connected state.➤ When the inverter is powered on, the AC-LOAD port is live. If you need to maintain the AC-LOAD, please powered off the inverter, or it may cause electric shock.
---	---

Residential hybrid inverter wiring system (schematic structure, not electrical wiring standard).

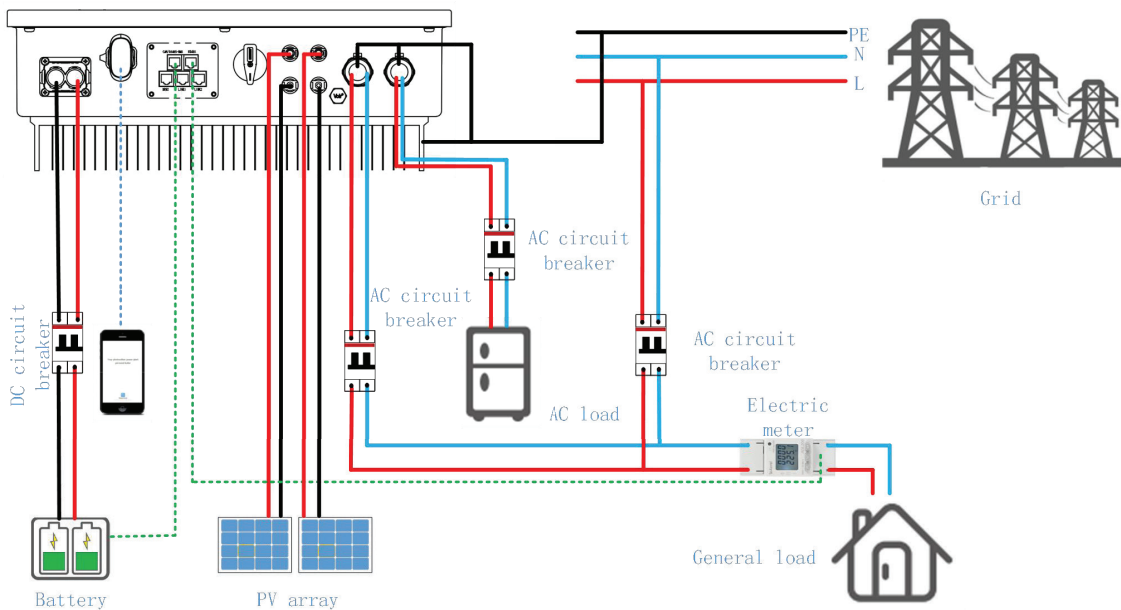

Recommended circuit breaker specifications: DC circuit breaker 120A; AC circuit breaker: 40A.

System electrical connection

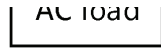

If AC load needs to be connected to the Grid, a single-pole double-throw switch is required, as shown in the following figure.

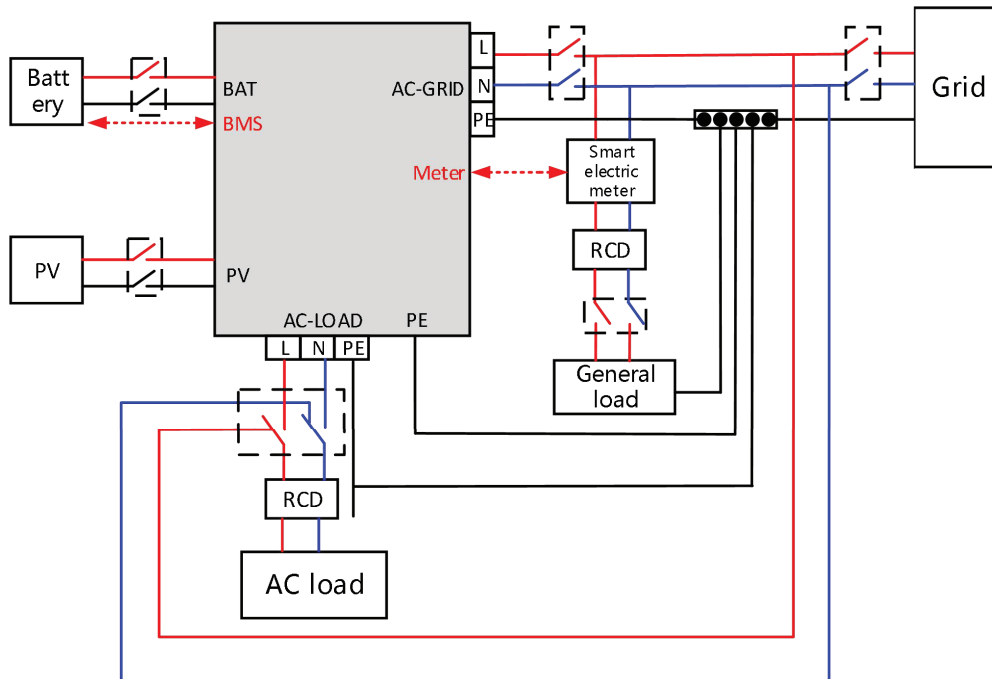



Note: AC load can not be connected to the Grid and the Inverter at the same time.

6.2 Wiring Instructions for External Ports

Table 6-1 Cable models and specifications

Port	Definition	Cable type	Cable size
	+: Positive pole of battery	Outdoor multi-core copper cable	Conductor cross-sectional area: 16mm ² ~25mm ²
	-: Negative pole of battery		
	+: Positive pole of PV	Outdoor multi-core copper cable	Conductor cross-sectional area: 4mm ² ~6mm ²
	-: Negative pole of PV		

 <p>AC LOAD</p>	Load	L3	Outdoor multi-core copper cable	Conductor cross-sectional area: 6mm ² ~10mm ²
N				
PE				
 <p>AC GRID</p>	Grid	L3	Outdoor multi-core copper cable	Conductor cross-sectional area: 6mm ² ~10mm ²
N				
PE				

6.3 Connecting Protective Earth (PE)

	<p>Since the inverter is a transformerless type, it is required that the positive and negative poles of the PV array cannot be grounded, Otherwise, it will cause fault to the inverter. In the PV power generation system, all non-current-carrying metal parts (such as brackets, distribution cabinet housing, inverter housing, etc.) should be connected to the ground.</p>
---	--

Step 1: Use yellow-green outdoor cable $\geq 4\text{mm}^2$, Strip the insulation layer of the grounding cable to an appropriate length with wire stripper;

Step 2: Put the wire core stripped of the insulation layer into the conductor crimping area of the OT terminal, and press it tightly with crimping pliers;

Step 3: Fix the OT terminal with M6 inner hexagon screws, and the recommended tightening torque is $5\text{N}\cdot\text{m}$.

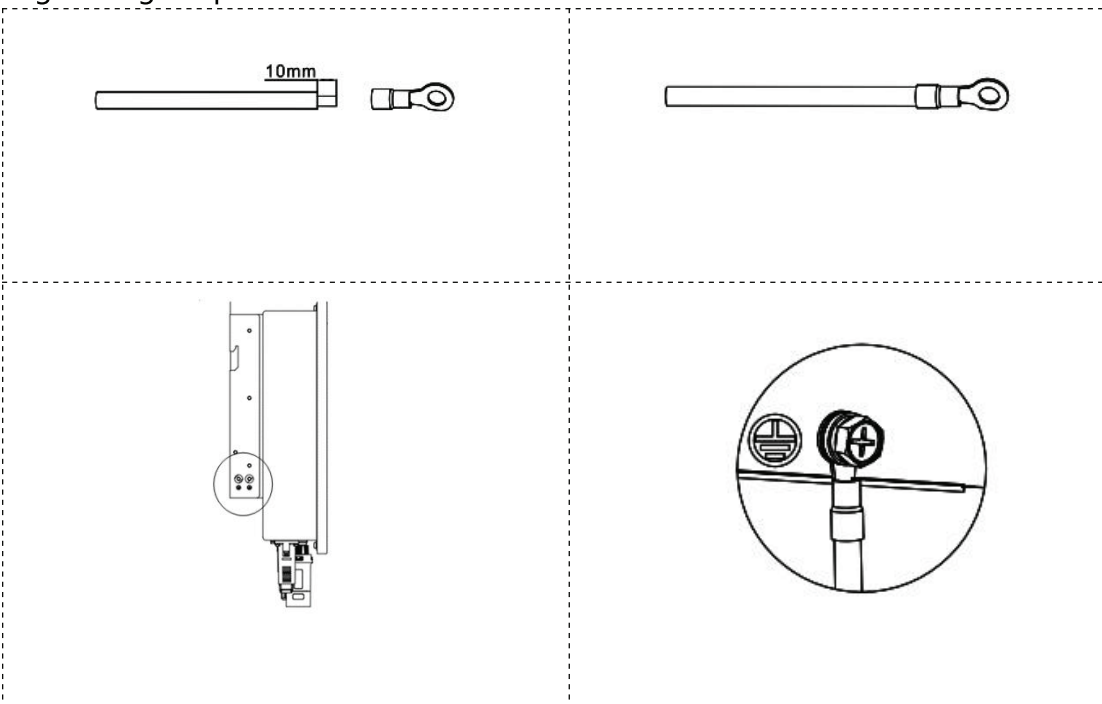

6.4 Connecting PV Cables

	<ul style="list-style-type: none">➤ Do not connect the same PV string to multiple inverters, or the inverter may be damaged.➤ Before connecting the PV strings to the inverter, please confirm the following information, or it may cause permanent damage to the inverter, and even cause a fire and result in
---	--

	<p>personal and property losses.</p> <ul style="list-style-type: none"> ➤ Please ensure that the maximum short-circuit current and maximum input voltage of each PV are within the allowable range of the inverter. ➤ Please ensure that the positive pole of the PV string is connected to the PV+ of the inverter, and the negative pole of the PV string is connected to the PV- of the inverter.
	<p>The PV string output does not support grounding. Before connecting the PV string to the inverter, ensure that the minimum insulation resistance of the PV string to ground meets the minimum insulation resistance requirements.</p>

Step 1: Check and ensure that the PV knob switch is set to "OFF".

Step 2: According to the cable model and specification in Table 6-1, cable with appropriate type and specification, then strip the cable insulation layer. The specific stripping length is shown in the figure below.

Step 3: Insert the positive and negative cables with the insulation layer stripped into the positive and negative metal terminals respectively, and use crimping pliers to press the cable and the metal core of the terminal tightly to ensure that the cable and the metal core are crimped firmly.

Step 4: Pass the crimped positive and negative cables through the lock nut, and insert them into the corresponding plastic shells until you hear a "click". This indicating that the metal core has been snapped into place, and tighten the lock nut.

Step 5: Check the positive and negative poles with a multimeter. After confirming that they are correct, insert them into the PV input terminal of the inverter.

To remove the PV connector from the inverter, you can use a disassembly wrench to insert into the fixing bayonet, press down firmly, and carefully remove the DC connector.

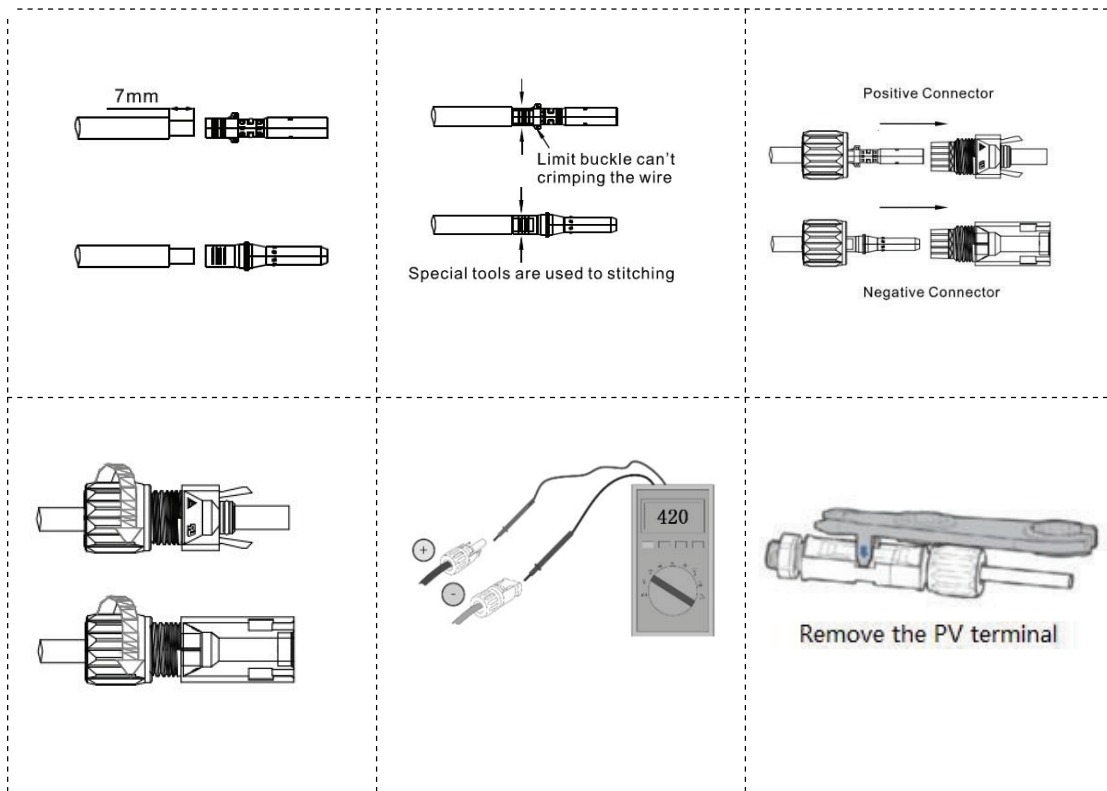

6.5 Connecting the Battery Cable

	<ul style="list-style-type: none"> ➤ Battery short circuit may cause personal injury, and the instantaneous high current caused by the short circuit may release a large amount of energy, which may cause a fire. ➤ Before connecting the battery cable, please confirm that the inverter and the battery are powered off, and the front and rear switches of the equipment are disconnected. ➤ When the inverter is running, it is forbidden to connect or disconnect the battery cable, or the operation may cause electric shock. ➤ Do not connect the same battery pack to multiple inverters, or the inverter may be damaged. ➤ Do not connect loads between the inverter and the battery. ➤ When connecting the battery cable, please use insulated tools to prevent accidental electric shock or short circuit of the battery. ➤ Please ensure that the open circuit voltage of the battery is
---	---

	within the allowable range of the inverter.
	<ul style="list-style-type: none"> ➤ When wiring, the battery cable should match the "BAT+" and "BAT-" of the battery terminal completely. If the cable is connected incorrectly, the equipment will be damaged. ➤ Please make sure that the wire core is completely inserted into the terminal wiring hole without being exposed. ➤ Make sure the cable connection is tight, or the terminal may be overheated and the equipment may be damaged when it is running.

Step 1: According to the cable model and specification in Table 6-1, select the appropriate cable type and specification, and strip the cable insulation layer;

Step 2: Put the wire core stripped of the insulation layer through the waterproof plug and the battery junction box, and then press the OT terminal tightly;

Step 3: Lock the crimped positive and negative cables into the corresponding terminals respectively, with a locking torque of 3.5N•m;

Step 4: Use a multimeter to check the positive and negative poles to ensure that the open circuit voltage is less than 60V;

Step 5: Install the rear cover of the waterproof plug.

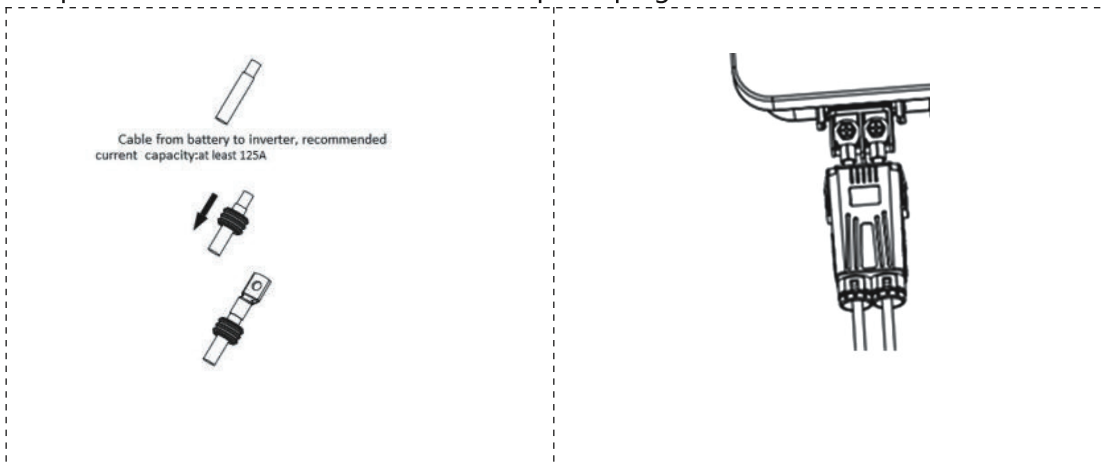

6.6 Connecting Off-grid Port (AC LOAD) and Grid-connected Port (AC GRID)

	<ul style="list-style-type: none">➤ When wiring, the AC wire should fully match the "L", "N" and grounding ports of the AC terminal. If the cable is connected incorrectly, it will cause equipment damage.➤ Please make sure that the wire core is completely inserted into the terminal wiring hole without being exposed.➤ Please ensure that the insulating plate at the AC terminal is clamped tightly without loosening.➤ Make sure the cable connection is tight, or the terminal may be overheated and the equipment may be damaged when it is running.
---	--

Step 1: According to the cable model and specification in Table 6-1, select the appropriate cable type and specification, and strip the cable insulation layer. For the specific stripping length, refer to the figure below;

Step 2: Unlock the terminal according to the figure, and pass the stripped cable through each part of the terminal;

Step 3: Press the terminal on the cable conductor core, lock the cable in the lock hole on the terminal according to the mark, and fasten it with a screwdriver;

Step 4: After plugging in the terminal shell and hearing a "click", tighten the waterproof nut clockwise to ensure that the cable is firmly connected;

Step 5: Connect the connected load terminal to the load port of the inverter, push it forward until a "click" sound is heard, which indicates the load terminal and the load port of the inverter is well connected.

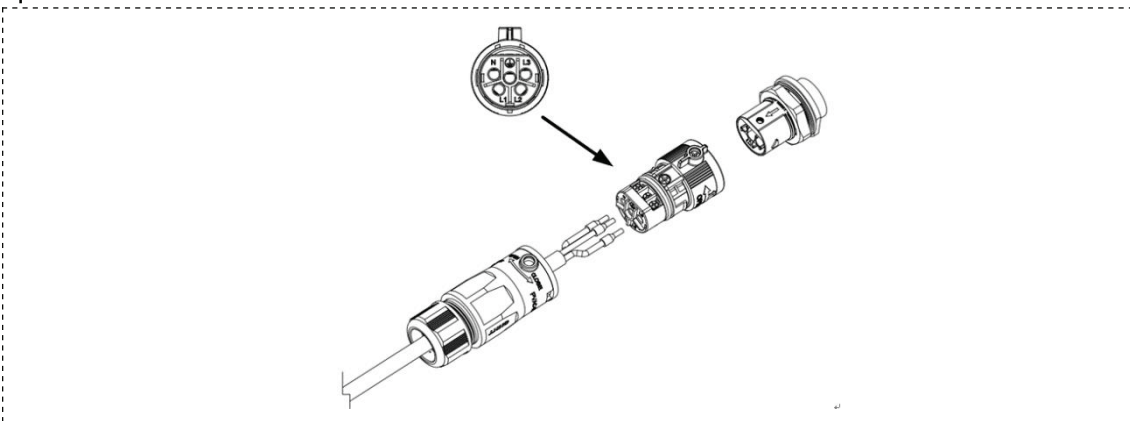

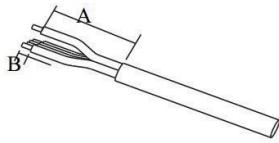

A:15~25mm
B:6~8mm

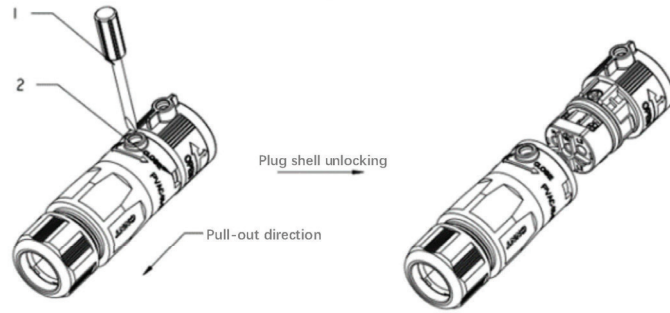

Unlocking operation:

1. Insert a flathead screwdriver or cross screwdriver (diameter < 3-5mm) into the hole shown on the left, and turn clockwise to tighten the screw (the screw and nut are loose before turning).
2. Then press the buckles (mark 2) on both sides of the shell with a screwdriver in turn, and apply a backward pull-out force (as shown by the arrow) to the shell while pressing.
3. The pull-out force of the outward force will make the buckle and shell loose. After pressing the two buckles, the shell can be separated from the front of the plug (as shown in the right picture).

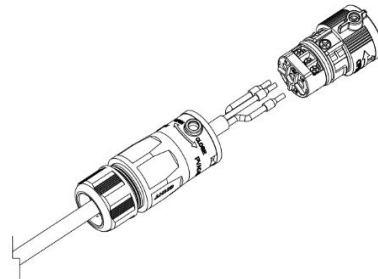
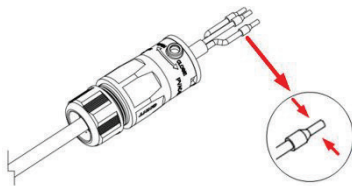

6.7 Installing WIFI/Bluetooth/4G Module

The collector is connected to WIFI/Bluetooth module by default and is used for remote monitoring and control of the inverter.



Indicator light description of WIFI/Bluetooth module

No.	Status	Description
1	RUN	Indicates normal operation, flashing every second.
2	COM	Indicates that the equipment data can be collected; it is always on and goes out for a short time, goes out when sending data, and turns on after receiving the data and verifying it is correct.
3	NET	<p>Network status indicator.</p> <p>Flashing quickly: Searching for network, 20ms on, 180ms off.</p> <p>Always on: Connected to the network.</p> <p>Flashing slowly: The cloud platform has been registered successfully, 500ms on and 500ms off.</p>

6.8 Connecting Communication Cables

Multi-function communication port, including BMS communication, meter communication, DRMS, external dry contact signal and parallel communication.

Step 1: Pass the cables through the waterproof cover of the signal interface and their respective waterproof plugs, and crimp the RJ45 terminals according to the order of the pins.

Step 2: Plug the cable into the communication port on the inverter side.

Step 3: Fasten the waterproof cover with screws.

Step 4: Tighten the waterproof nut.

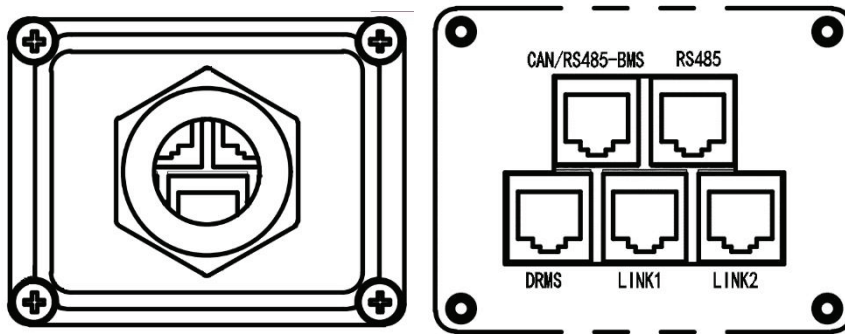

The pin assignment of the RJ45 socket of the communication cable is as follows:

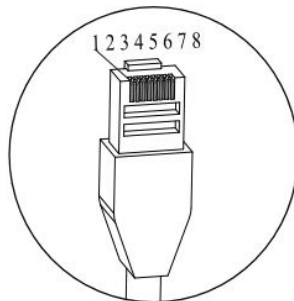

The interfaces are described as follows:

CAN/RS485-BMS interface

PIN	Definition	Function	Remarks
1	GND_SELV	Communication ground	Communicates with lithium battery BMS, and can provide CAN
2	GND_SELV	Communication ground	
3	/	NC	
4	CAN_A_H	CAN high bit data	

5	CAN_A_L	CAN low bit data	and RS485 communication for lithium batteries adaptively
6	/	NC	
7	RS485_A_BMS	RS485 differential signal A	
8	RS485_B_BMS	RS485 differential signal B	

Note: ① When communicating with a lithium battery, you need to pay attention to the order of the battery's communication ports and pin definitions;

② Pay attention to whether there is a prohibition on wiring at the battery port;

DRMS interface

PIN	Definition	Function	Remarks
1	DRM1/5	DRMS interface is suitable for the Australian AS-NZS-4777.2 (some European requirements) safety standard	DRMS logical interface
2	DRM2/6		
3	DRM3/7		
4	DRM4/8		
5	REF GEN		
6	COM LOAD		
7	OP-	Normally open dry contact signal ($\leq 1A$)	External dry contact interface
8	OP+		

LINK 1&2 interface (parallel communication)

PIN	LINK1 definition	LINK2 definition	Remarks
1	CON2_AO	CON1_AO	Parallel signal
2	CON2_BO	CON1_BO	

3	CON2_AI	CON1_AI	
4	CON2_BI	CON1_BI	
5-6	/	/	
7	CON_SyncH	CON_SyncH	
8	CON_SyncL	CON_SyncL	

RS485 interface (electric meter communication)

PIN	Definition	Function	Remarks
1	GND_SELV	Communication ground	NC
2	GND_SELV	Communication ground	
3-6	/	NC	
7	RS485_A_EEM	RS485 differential signal A	Meter 485 communication
8	RS485_B_EEM	RS485 differential signal B	

Application notes:

PIN7 and PIN8 are used for meter communication and need to be connected to ports 21 and 22 of the meter respectively (Acrel ADL200 has a built-in CT single-phase electronic kilowatt-hour meter). The meter L/N is the incoming line side of the power grid, and L' /N' is the outgoing line side (load side). Connect the meter as shown in the figure below.

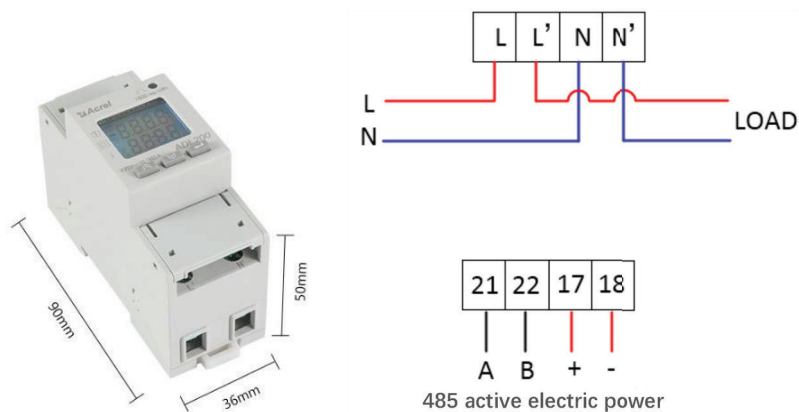

6.9 Parallel Wiring Operation

The terminal wiring steps of the parallel communication cable are as follows:

Step 1: Put the network cable plug on the table, and make sure the metal contact piece of the connector is facing up.

Step 2: Use a wire stripper to peel off the outer sheath of the network cable and uncover about 1.5cm of the insulation layer.

Step 3: Insert the LINK1 port to arrange the core sequence of the network cable. The order of the wire cores from left to right is: orange & white -orange-green & white-blue-blue & white-green-brown & white-brown. Insert the LINK2 port to arrange the core sequence of the network cable. Insert the cores of the network cable into the LINK2 port and arrange the cores in the order from left to right: green & white-blue-orange & white-orange-blue & white-green-brown & white-brown. Straighten each strand and arrange them in the correct order.

Step 4: Insert the cores into the slots of the plug, making sure that each core is fully inserted into the slot without being twisted or bent.

Step 5: Use pliers to fix the plug on the network cable, make sure the connection between the plug and the network cable is firm.

LINK1 port wiring method:

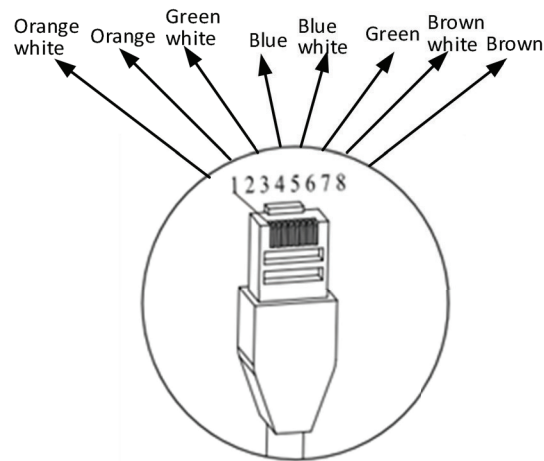

LINK2 port wiring method:

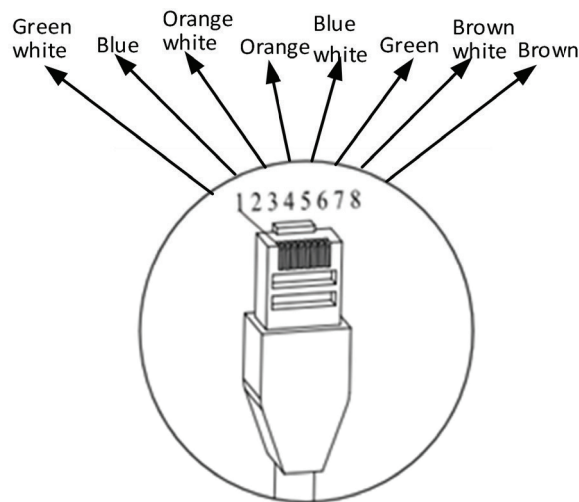



Parallel wiring is as follows:

Application notes:

- 1) Up to 6 parallel inverters of the same model are supported, and can be set to parallel mode or three-phase mode;
- 2) Make sure that the inverters are connected to parallel cables;
- 3) The length specifications of the cables connecting the load end of the inverter to the AC LOAD end of each of the equipment must be consistent to ensure that the loop impedance is consistent, and the load current distribution to each inverter is approximately equal;
- 4) Make sure that the load power is less than the maximum power of parallel power.



6.10 Meter Operation and Display

(1) Description of key functions

Icon	Name	Function
	Up key for voltage and current	Check the voltage and current in the view interface Scroll up and flash shift in the programming interface
	Down key for power	Check the power in the view interface Scroll down and modify the flashing bit in the programming interface
	Electricity Programming confirmation key	Check electricity in the view interface Press for 3 seconds to enter/exit menu Press OK in the programming interface to save the settings

(2) Display instructions

Display the total active energy after power on. The page turning can be realized through three types of viewing keys. The sequence of display pages is described as follows:



	Voltage, current, frequency, time, MODBUS protocol address, baud rate, check digit, DL/T645 address, software version number, full display detection.
	Total active power, total reactive power, total apparent power, and total power factor.
	Total active energy, forward active total energy, reverse active total energy, total active spike energy, total active peak energy, total active flat energy, total active valley energy, total reactive energy, forward total reactive energy, reverse reactive total energy, total reactive spike energy, total reactive peak energy, total reactive level energy, and total reactive valley energy.

Application notes:

- The above list is the name of all display interfaces of ADL200 meter with multi-rate function. The three buttons can switch different types of display content, and the switching sequence is as above;

- For ADL200 meters without multi-rate function, the date, time and time-of-use electric energy (that is, the electric energy in the four periods of spike, peak, flat, and valley) are not displayed.

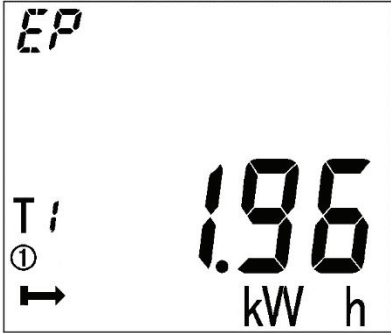
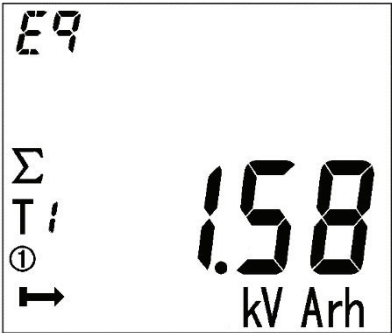

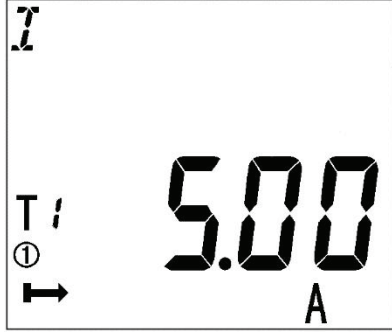
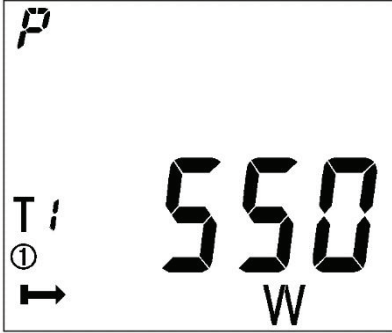
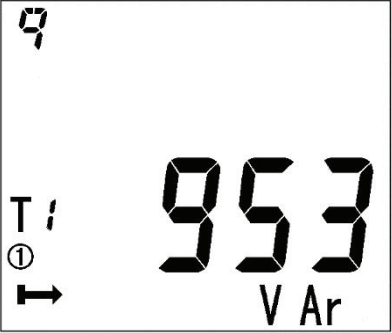

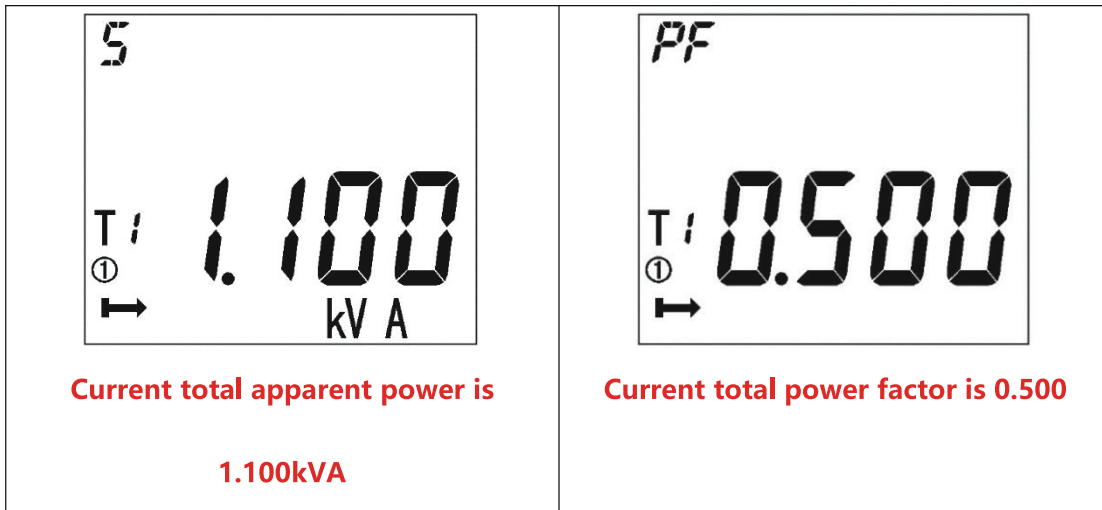
Example of display interface

 <p>Current total active power is 1.96kWh</p>	 <p>Current total reactive power is 1.58kWh</p>
 <p>Current voltage is 220.0V</p>	 <p>Present current is 5.00A</p>
 <p>Current total active power is 550W</p>	 <p>Current total reactive power is 953VAr</p>



Note: The above is only a part of the display interface, and the display modes of other interfaces are similar to the above figure. The display meaning can be judged according to the information displayed in the interface.

(3) Programming interface

Under any display item in the measurement display menu, press and hold  to enter the "PASS" interface, enter the password and then press ; if the password is entered incorrectly, it will return "0000", please re-enter the password; if the password is correct, the parameters can be set. After setting, press and hold  to enter the "SAVE" interface, select "YES" and then press  to save and then exit, select "No" and then press  to exit without saving. The programming interface flow is as follows:

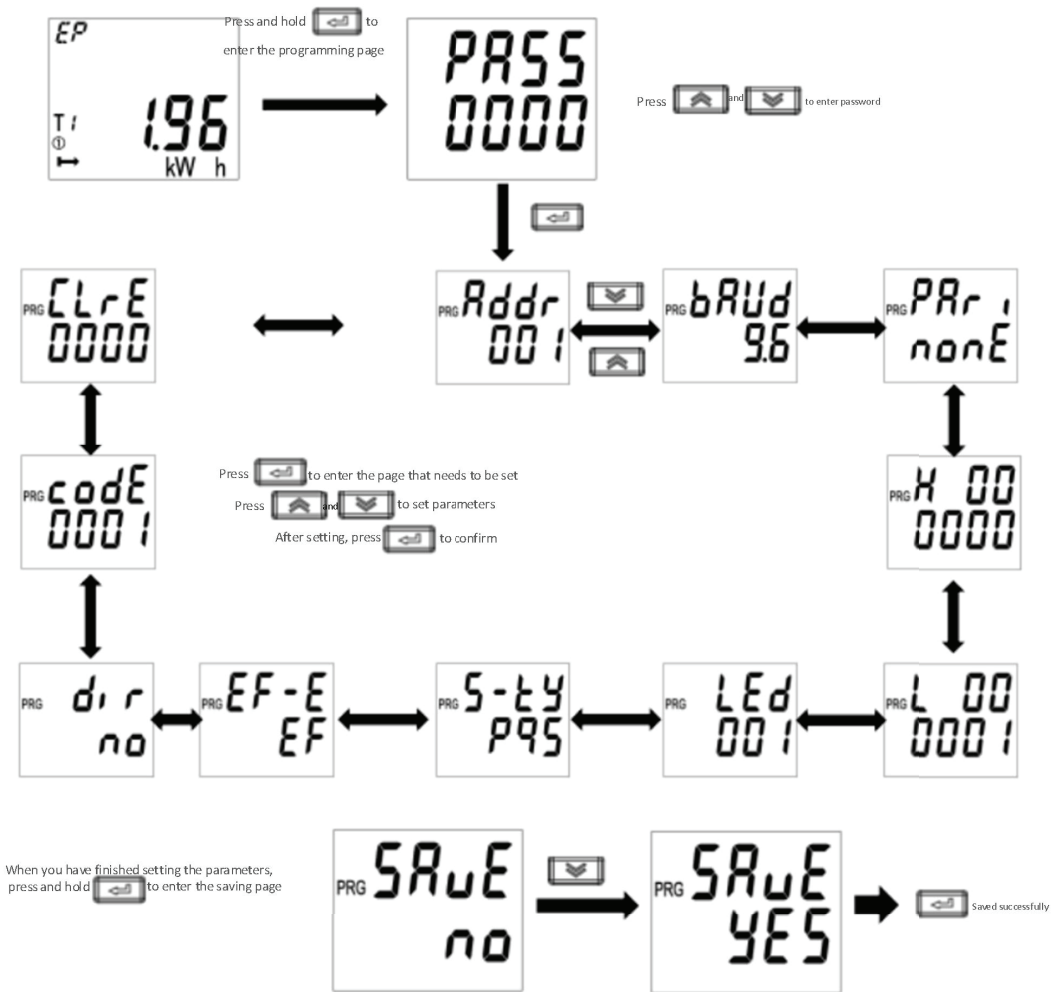

Application notes:

- The initialization password is 0001
- The communication address is set to 0001
- The baud rate is set to 38400

(4) Data items can be set

Setup menu description

No.	Secondary menu		
	Symbol	Meaning	Range
1	ADDR	Communication address setting	1-254

2	Baud	Baud rate selection	1200、2400、4800、9600、 19200、38400
3	Pari	Parity selection	None、Odd、Even
4	HI	DL/T645 high 6-bit meter number	000000-999999
5	LO	DL/T645 low 6-bit meter number	000000-999999
6	LED	Backlight time setting	0-255 minutes, 0 is always on
7	S-TY	Apparent power calculation method	PQS,RMS
8	EF-E	Multi-rate function	EF-with multi-rate E-Without multi-rate
9	DIR	Current direction	No-Forward Yes-Reverse
10	CoDE	Password setting	1-9999
11	CLrE	Clear	0-9999

7. Equipment Trial Run

7.1 Check before Power-on

No.	Check item
1	The inverter is firmly fixed on the wall mounting bracket.
2	The cable binding meets the routing requirements, the distribution is reasonable, and there is no damage.
3	The PV+/PV-, BAT+/BAT- wires are firmly connected, the polarity is correct, and the voltage meets the connection range.
4	The DC switch is correctly connected between the battery and the inverter, and the DC switch is disconnected.
5	The AC circuit breaker is correctly connected between the grid port of the inverter and the grid, and the circuit breaker is disconnected.
6	The AC circuit breaker is correctly connected between the load port of the inverter and the power grid, and the circuit breaker is disconnected.
7	For lithium batteries, please make sure the communication cable is properly connected.

7.2 First Power-on

Important: Follow the steps below to turn on the inverter.

- 1) Make sure the inverter is not working;
- 2) Turn on the rotary switch of the inverter (when connected to PV);
- 3) Turn on the battery and close the DC switch between the battery and the inverter;
- 4) Close the AC circuit breaker between the grid port of the inverter and the grid;
- 5) Close the AC circuit breaker between the load port of the inverter and the load;
- 6) The inverter starts to run after the self-check is successful.

8. System Commissioning

8.1 Indicator Description

The LED indicator light is in the middle of the equipment panel, and indicates the status of the inverter through three colors of red, green and blue.

Color of indicator light	Indicator status	Corresponding description	Remarks
Green	Always on	Grid connected	/
	Blinking	Standby (connected to the grid)	/
Blue	Always on	Off grid	/
	Blinking	Standby (off-grid)	/
Red	Always on	Non-recoverable fault	Inverter needs power-off inspection
	Blinking 2s/time	Alarm	Non-stop or reduced power operation
	Blinking 0.5s/time	Alarm	The inverter is shut down, waiting for the recovery condition to be met

8.2 App Introduction

Users need to choose a WiFi device or 4G device when using the app.

Please contact the manufacturer for ESS LINK operation and use, and refer to the ESS LINK operation and use manual.

IOS version: please scan the QR code below to obtain or go to the App Store to search for ESS LINK to download

Android version: Please scan the QR code below to obtain.



Android domestic QR code



Android foreign QR code



IOS Domestic and foreign QR code

9. Troubleshooting and Maintenance

This section will help you figure out the causes of malfunction during inverter operation.

9.1 Regular Maintenance

	<p>Make sure the inverter is powered off.</p> <p>When operating the inverter, please wear personal protective equipment.</p>
---	--

Maintenance items	Maintenance method	Maintenance cycle
System cleaning	Check the heat sink for foreign objects and dust. Clean the heat sink if necessary.	1 time/half a year~1 time/year (depending on ambient dust content)
DC switch	Turn the DC switch on and off 10 times continuously to ensure that the DC switch functions normally.	1 time/year
Electrical connection	Check whether the cable connection is loose or disconnected, whether the appearance of the cable is damaged, or whether there is copper leakage.	1 time/half a year~1 time/year
Airtightness	Check whether the leakproofness of the inverter inlet hole meets the requirements. If the gap is too large or not sealed, it needs to be sealed again.	1 time/year
THDi test	According to the requirements of Australia, Zref should be added between the inverter and the grid in the THDi test. L:0.24 Ω + j0.15 Ω ; N:0.16 Ω +j0.10 Ω L:0.15 Ω + j0.15 Ω ; N:0.1 Ω + j0.1 Ω	Depending on demand

10. Technical Parameters

Product model	Isuna 3000S	Isuna 3600S	Isuna 4000S	Isuna 4600S	Isuna 5000S	Isuna 6000S
Battery parameters						
Number of battery input	1					
Battery type	Lithium battery					
Nominal battery voltage	51.2V					
Battery voltage range	42V-58V					
Max. charging voltage	60V					
Nominal charging/ discharging power	3kW	3.6kW	4kW	4.6kW	5kW	5kW
Max. continuous charging/ discharging	75A	85A	85A	100A	100A	100A

current						
Communication port	RS485/CAN					
PV input						
Number of MPPT	2					
Max. input power①	4500Wp	6000Wp	6000Wp	7500Wp	7500Wp	9000Wp
Max. input voltage	600V					
Starting voltage	95V					
MPPT voltage range	80~550V					
Full load MPPT voltage range	350~500V					
Nominal input voltage	360V					
Numbers of MPPT	2					
Max. input string per	1					

MPPT	
Max. input current	13A/13A
Max. short-circuit current	18A/18A

Remark ①: Two independent PV channels are recommended, and the maximum power of a single PV does not exceed 4500W.

Grid-connected parameters						
Nominal output power	3000W	3600W	4000W	4600W	5000W	6000W
Max. input power from grid	3600W	5000W	5000W	6000W	6000W	6000W
Max. output current	13.6A	16.4A	18.2A	20.8A	22.7A	27.2A
Max. input current from grid	16.4A	22.7A	22.7A	27.2A	27.2A	27.2A
Nominal grid voltage	230V					
Grid voltage range	184-276V					

Nominal grid frequency	50Hz					
Frequency range	45Hz~55Hz/55Hz~65Hz					
Power factor	~1 (0.8 lead-0.8 lag)					
THDi(@rated power)	<3%					
Off-grid parameters						
Nominal output power	3kVA	3.6kVA	4kVA	4.6kVA	5kVA	6kVA
Max. output power	3kVA	3.6kVA	4kVA	4.6kVA	5kVA	6kVA
Max. output current	13.6A	16.4A	18.2A	20.8A	22.7A	27.2A
Nominal voltage	230V					
Nominal frequency	50Hz					
THDu (@linear load)	<2%					
Switching time	<20ms					
Efficiency						

European efficiency	97.2%	97.3%	97.3%	97.4%	97.5%	97.5%
Max. efficiency	97.5%	97.5%	97.8%	97.8%	98%	98%
Max. battery charging/ discharging efficiency	95.2%					
Protection						
Insulation resistance detection	Integrated					
Residual current monitoring	Integrated					
Input reverse polarity protection	Integrated					
Islanding protection	Integrated					
Overvoltage and	Integrated					

overload protection	
AC short circuit protection	Integrated
AC side overvoltage level	III
Battery and PV overvoltage level	II
Surge protection	Integrated
Lightning protection	Integrated
General parameters	
Installation method	Wall-mount
Size(W*H*D)	500mm*470mm*180mm (without terminals)
Weight	21kg
Standby power	≤10W

consumption	
Operating temperature range	-25°C~+60°C (>40°C, Derated operation)
Permissible humidity range	0~100%
Noise	<25dB (A)
Permissible altitude	<4000m (≤3000m under full load, every increase of 100m, the power will be reduced by 5%)
Condensation method	Self-heating and heat dissipation
Ingress protection grade	IP65
Monitoring	H5/LED/APP/WIFI/4G/Bluetooth (optional)
Communication port	RS485/CAN/DRED/dry contact/parallel communication
Performance and Certification	

Parallel function	Yes
Standard warranty	10 years
Safety standard	IEC 62109-1, IEC 62109-2, EN 62109-1, EN 62109-2
EMC	EN61000-6-1, EN61000-6-2, EN61000-6-3, EN61000-6-4
Grid-connected standard	VDE-AR-N 4105, VDE V 0126-1-1, G98/G99, CEI 0-21, EN50549 NRS 097-2-1, AS 4777.2, R25

RoHS



UK
CA

